

**NOTES**

1. EXISTING GROUND SURFACE TOPOGRAPHY IS FROM AUTOCAD DRAWINGS BY JOHNSON ENGINEERING WITH SUPPLEMENTAL ROAD ELEVATIONS BY ANDERSON SURVEY GROUP.
2. EXISTING GROUND CONTOURS LINES SHOWN ARE 25' INTERVALS.
3. APPROXIMATE AREAS WITH SLOPE MORE THAN 15% ARE SHOWN COLORED. UNHATCHED AREAS ARE GENERALLY 15% SLOPE OR FLATTER.

NATURE'S VIEW ESTATES  
SUBDIVISION  
Boise County, Idaho

**Focus Engineering**  
Civil-Geotechnical-Environmental-Structural  
3835 West Scenic Drive, Boise, Idaho 83703  
(208) 395-1979 (208) 395-2399 fax focus@cablone.net

REVISIONS:

1	_____
2	_____
3	_____
4	_____
5	_____
6	_____
7	_____

PRELIMINARY  
DRAWING  
NOT FOR CONSTRUCTION

SLOPE ANALYSIS			
Number	Minimum Slope	Maximum Slope	Color
1	0.00%	15.00%	■
2	15.00%	35.00%	■
3	35.00%	55.00%	■
4	55.00%	5000.00%	■

**SLOPE ANALYSIS PLAN**

**SLOPE ANALYSIS PLAN**  
SCALE: 1"=80'

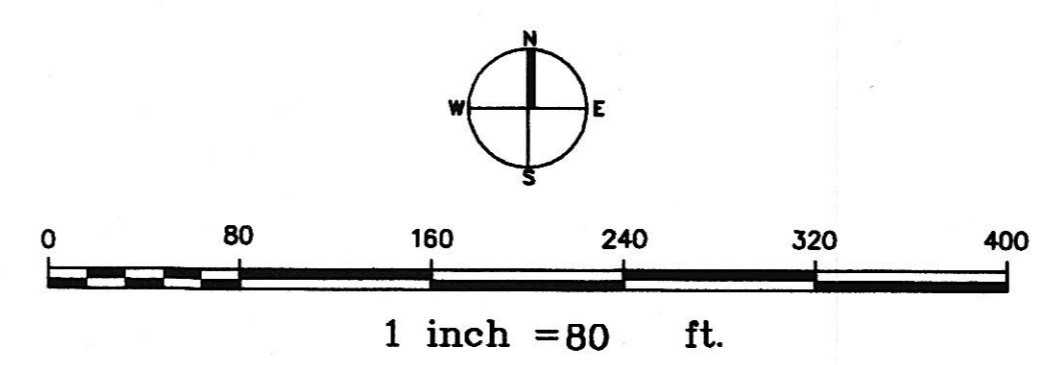

PROJECT NO: 06037  
DATE: 02-07-07  
DRAWN BY: CAG

C1.7